



Eclipse AutoTite

Automatic Shut-Off Valves

Series 2000 AT

Version 2

Parameter	Specifications			
Ambient Temperature Limits	-20° to 130°F (CSA, FM & UL) <i>Below 32°F, the gas must be free of water vapor which could condense and freeze within the valve.</i>			
Maximum Operating Pressure	30 psi			
Gases	Approved for air, natural gas, propane, and butane. For other gases, contact Eclipse.			
Nominal Opening Time	10 seconds @ 60 Hz; 20 seconds @ 50 Hz <i>Temperature can affect the opening time.</i>			
Maximum Closing Time	1 second			
Electrical Actuator	220V/50Hz	110V/50Hz	120V/60Hz	220V/60Hz
Amps Inrush	13.0	13.0	7.0	7.0
Amps Opening	2.25	1.85	1.10	0.92
Amps Holding	0.12	0.11	0.05	0.05
Electrical-Aux Switches	4 SPDT: 2 adjustable, open position, and 2 factory set proof-of-closure. <ul style="list-style-type: none"> • 120V: 15 amps • 240V: 7.5 amps Maximum total connected load for switches: 1800VA			
Agency Approvals		UL Listed (File - MH5769)		
		FM Approved (File - J.I. 0Z0A7.AF & J.I. IZ5A0.AF)		
		CSA Certified (File - 112698/162582)		
Enclosure Ratings	NEMA 1, 2, 3, 3s, 4, 12 & 13 (Combination general purpose, water tight, dust tight, drip tight, and oil tight enclosure.)			

Power Equipment Company
 2011 Williamsburg Road
 Richmond, Virginia 23231
 T – (804) 236-3800
 F – (804) 236-3882
 www.peconet.com

ECLIPSE[®]
 Innovative Thermal Solutions

Valve Capacities Pressure Drop Across Valve

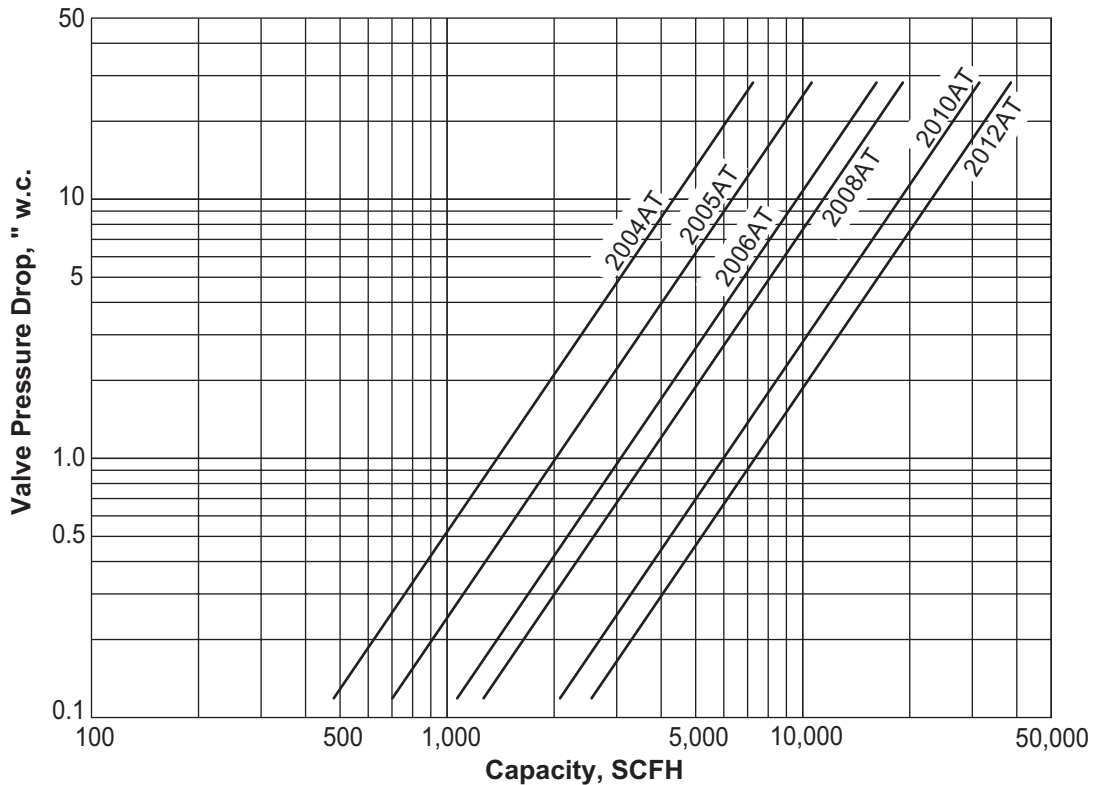

Flows for natural gas (0.6 sg) at standard conditions of 60° F, 14.7 psia.
Multiply capacities by the factors below for other gases:

Butane (2.0 sg).....	0.548
Propane (1.55 sg).....	0.632
Air (1.0 sg).....	0.775

Flows corrected to standard conditions (60°F, 14.7 psia) using the following formula:

$$Q_n = Q \times \left[\frac{520}{460 + T} \right] \times \left[\frac{P_a + P_1}{14.7} \right]$$

Flow - Pressure Drop formula:

$$Q = 1360 \times C_v \times \sqrt{\frac{(P_1 - P_2) \times P_2}{(G \times T)}}$$

Estimated Pressure Drop formula:

$$\Delta P = \Delta P_n \times \left[\frac{Q}{Q_n} \right]^2 \times \frac{(460 + T)}{520} \times \frac{14.7}{(P_a + P_1)}$$

Q = Gas flow (cfh)

P_a = Atmospheric pressure (psia)

P₁ = Inlet pressure (psi)

P₂ = Outlet pressure (psi)

T = Gas temperature (°F)

G = Specific gravity

C_v = 25 (2004 AT)

36 (2005 AT)

55 (2006 AT)

63 (2008 AT)

106 (2010 AT)

129 (2012 AT)

Q_n = Gas flow (scfh) under standard conditions

ΔP_n = Pressure drop ("w.c.) under standard conditions

Valve Dimensions

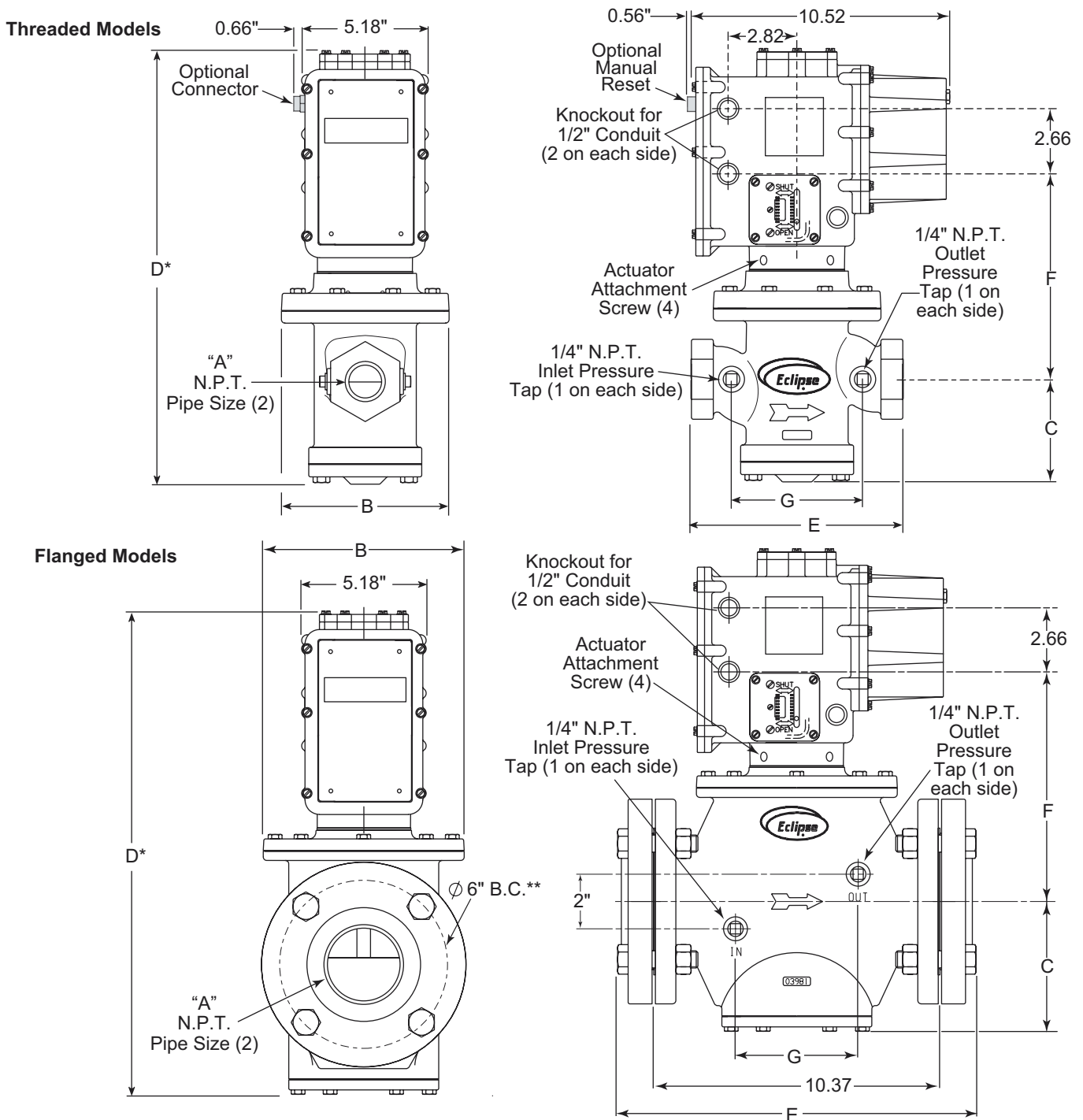

Model Number	Connection Type	Dimensions in Inches								Net Lbs
		A	B	C	D*	E	F	G	H	
2004 AT	Threaded	1.00	5.75	3.50	16.34	7.25	7.70	4.50	34	34
2005 AT	Threaded	1.25	5.75	3.50	16.34	7.25	7.70	4.50	34	34
2006 AT	Threaded	1.50	5.75	3.56	16.85	9.00	8.15	5.00	40	40
2008 AT	Threaded	2.00	5.75	3.56	16.85	9.00	8.15	5.00	40	40
2010 AT	Flanged	2.50	7.37	4.75	18.78	12.87	8.91	4.50	85	85
2012 AT	Flanged	3.00	7.37	4.75	18.78	12.87	8.91	4.50	85	85

* Add 2" clearance to overall height for installation/removal of actuator.

** 3" flange bolt pattern is used for both 2010AT and 2012AT.

Mounting Information

The valve body with actuators can be mounted in any position.

Approximate radius of rotation required for installing threaded body valves is:

- 5-1/2" for 1 inch and 1-1/4 inch valves
- 6" for 1-1/2 inch and 2 inch valves
- 6-3/4" for 2-1/2 inch and 3 inch valves

Ordering Information

Select the Eclipse valve assembly part numbers based on the valve size and actuator type.

Actuator shipped detached from valve body.

AT Valve Part Numbers

Model Number	Pipe Size	Description	Assembly Part No.	Valve Body Only, Part No.	Actuator Only Part No.	Flange Kits
2004AT	1" NPT	110/120V, standard actuator	501600	501539	16000-2	---
	1" NPT	220/240V, standard actuator	501600-1	501539	16001-2	---
	1" NPT	110/120V, quick connector	501600-25	501539-1	10003259	---
	1" Rc	110/120V, standard actuator	501600-2	501539-2	16000-2	---
2005AT	1.25" NPT	110/120V, standard actuator	501601	501540	16000-2	---
	1.25" NPT	220/240V, standard actuator	501601-1	501540	16001-2	---
	1.25" NPT	110/120V, quick connector	501601-24	501540-1	10003259	---
2006AT	1.5" NPT	110/120V, standard actuator	501602	501541	16000-2	---
	1.5" NPT	220/240V, standard actuator	501602-1	501541	16001-2	---
	1.5" NPT	110/120V, quick connector	501602-24	501541-1	10003259	---
	1.5" Rc	110/120V, standard actuator	501602-2	501541-2	16000-2	---
2008AT	2" NPT	110/120V, standard actuator	501603	501542	16000-2	---
	2" NPT	220/240V, standard actuator	501603-1	501542	16001-2	---
	2" NPT	110/120V, quick connector	501603-24	501542-1	10003259	---
2010AT	2.5" NPT	110/120V, standard actuator	501604	501543	16000-2	501547
	2.5" NPT	220/240V, standard actuator	501604-1	501543	16001-2	501547
	2.5" Weld	110/120V, standard actuator	501604-2	501543	16000-2	501547-10
	2.5" Weld	220/240V, standard actuator	501604-3	501543	16001-2	501547-10
	2.5" NPT	110/120V, quick connector	501604-24	501543-1	10003259	501547
2012AT	3" NPT	110/120V, standard actuator	501605	501533	16000-2	501548
	3" NPT	220/240V, standard actuator	501605-1	501533	16001-2	501548
	3" Weld	110/120V, standard actuator	501605-2	501533	16000-2	501548-10
	3" Weld	220/240V, standard actuator	501605-3	501533	16001-2	501548-10
	3" Weld	110/120V, quick connector	501605-24	501533-1	10003259	501548

NOTE: Flange kits include ANSI Class 150, A105 forged steel flanges, Grade 2 zinc coated nuts, bolts and gaskets. Flanges are shipped in kit form with the actuator and valve body.

NOTE: Valve bodies can only be used with Eclipse 2000AT actuators. Use of other actuators will void all warranty and liability by Eclipse.

Power Equipment Company
2011 Williamsburg Road
Richmond, Virginia 23231
T – (804) 236-3800
F – (804) 236-3882
www.peconet.com

Data 756-1, 8/17/2010

ECLIPSE[®]
Innovative Thermal Solutions



Offered By:

Power Equipment Company
2011 Williamsburg Road
Richmond, Virginia 23231
Phone (804) 236-3800
Fax (804) 236-3882

www.peconet.com